

## 1. General

The specifications found in this technical rider serve to provide optimal work conditions and to eliminate any potential problems that can occur in preparation for the event to ensure the best results possible. Please pay close attention to the specifications to guarantee a smooth process. The equipment mentioned presents the minimum requirements and is conform to the usual quality criteria. Severe shortcomings can lead to the event not being held as agreed or its complete cancellation. We will gladly try to provide any equipment if needed.

The technical rider is part of our contract. Please do not hesitate to contact us after reading the rider to clarify any organizational matters:

## 2. Contact Person

Band

Julian Jauk

+43 664/91 47 506

office@ultimaradio.at

## 3. PA-System

The PA-system should provide a linear performance ranging from about 40Hz to 16kHz. Please consider frontfills and sidefills if the main PA-system should be unable to evenly cover the audience. 100 – 105db should be accomplishable in the audience area without activating the PA's limiter or causing it to distort. Preferred systems are d&b, Nexo, L'Acoustic, Meyer Sound. Additionally, insight into, and if necessary, access to the system controller should be provided.

## 4. FOH

- located centrally and slightly elevated, with appropriate distance to the audience.
- Even, clean area with 3x2 meters that needs to be protected from rain in open air areas
- 1,5x1 meter table for the mixer
- Platform needs to be in front of balconies or any other constructions
- appropriate power sockets and workspace lighting

### Preferred Consoles

- Allen Heath GLD/iLive
- Digico SD9/SD11/SD8
- Digidesign SC48/Profile/SL3
- Yamaha CL/QL/M7CL

## 5. Monitoring

· 6 monitors on 5 separate lines (2x for lead singer) are requested if possible. 2x in the front on one line, 4x in the back on 4 lines. At least 5 monitors on 5 lines. Preferred monitors would be models from d&b (M4, M6 max.).

## 6. Stage

- The stage needs to be at least 5x3,5m big, flat, stable, dry, clean and clear of any head-lights, cases or other items. Stage height should be at least 40cm.
- We need one riser with 3x2m at 40cm height in the back of the stage in a central position.
- The background of the stage should be covered with black duvetyn.
- Height of the headlights above the stage (measured from the top level of the stage) should be 4,5m.
- Possibility to install a 3,5x1,24m backdrop should be provided.
- Should there be any obstacles (bars, ramps) on stage or any difficulty meeting the specifications, please let us know.

## 7. Electricity

Performance/security measures need to be followed as indicated by the instructions for the sound/lighting system. 230 volts are required on stage; plug sockets type F; the connections need to be free of ground loops and must not have performance fluctuations.

## 8. Timetable - Soundcheck

The sound/lighting system needs to be wired, tested and ready to perform before sound-check. Our soundcheck does not take longer than one hour maximum under adequate conditions.

### Timetable

- 45min Stage Load In
- 45min Soundcheck

## 9. Light

We will bring our own independently controlled stagelights, consisting of four 100W LED columns. We kindly ask the lighting technician to turn off the hall lights completely at the beginning of the show for the entire set, while remaining on standby in case of any issues. Additionally, should there be any problems with our setup, we have the following minimum lighting requirements:

- White front light, also for the drummer
- Option to colorize the background of the stage (min. 6 LED headlights)
- Min. 4 moving headlights

Additionally, we kindly request the use of haze, not fog, to enhance our show as we see fit. Please avoid using low-quality fluid for this purpose.

# TECHNICAL RIDER

# ULTIMA RADIO

Version 06.01.2025

## 10. Staff

A technical director with all relevant keys and with decision-making power should be present upon the arrival of the band so we can make any arrangements in a timely manner if necessary.

Sound and lighting engineers as well as stagehands need to arrive in time and sober for the arranged soundcheck and need to be familiar with the sound and lighting system. We could use every helping hand during load in/load out and appreciate every extra support. We usually have our own sound engineer but will inform you if this should not be the case.

## 11. Stageplot

Unless otherwise agreed, we will not bring our own microphones. We would also like to ask you to provide cables and stands.

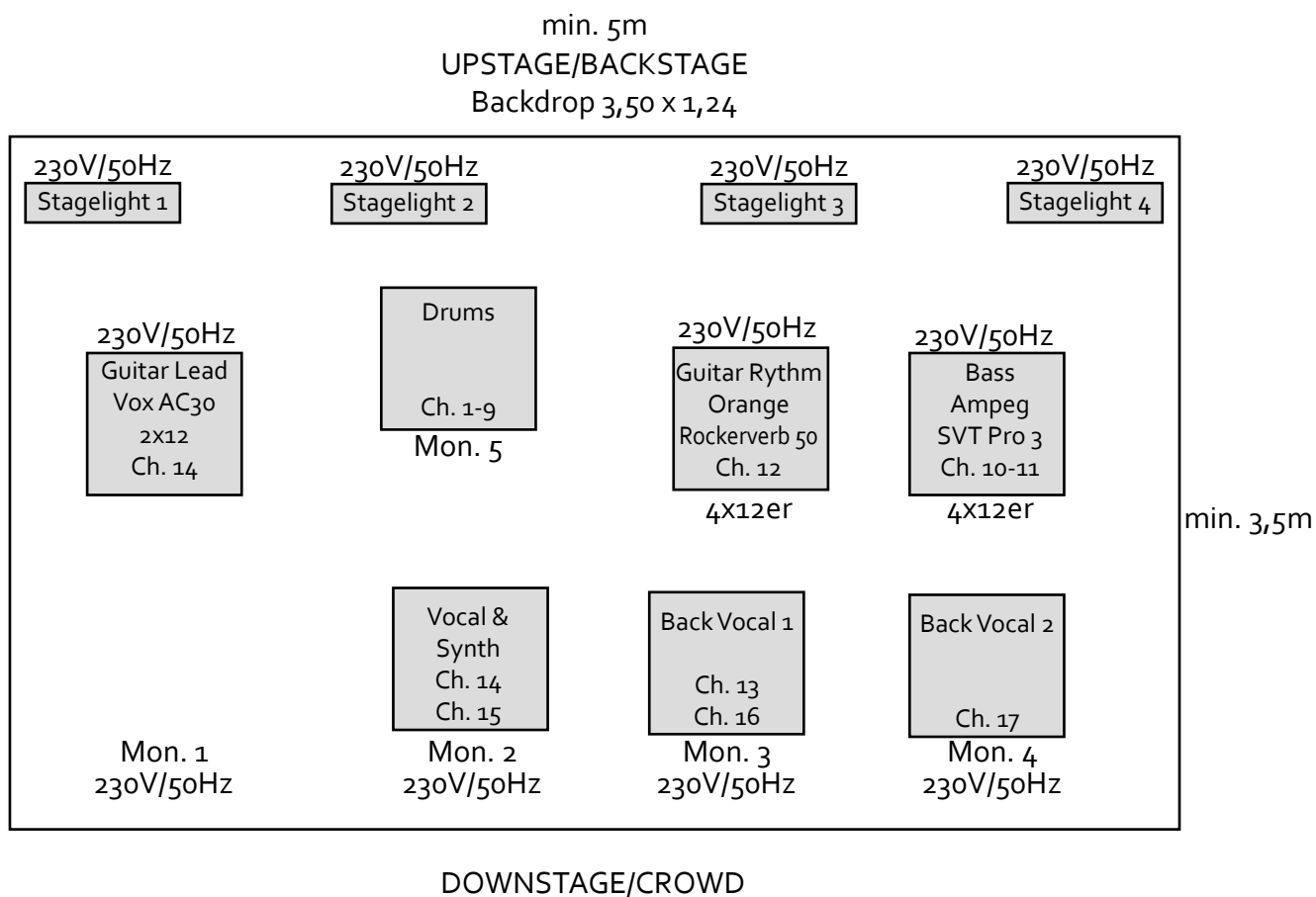

## 12. Channel List

Nr.	Channel	Microphone	Stand	Info
1	Bass Drum In	Shure Beta 91		
2	Bass Drum Out	Shure Beta 52A Audix D6	Small	
3	Snare Top	Shure Sm57	Clamp	
4	Snare Bottom	Shure Sm57 Sennheiser e604/e904	Clamp	
5	HiHat	AKG c451B/c391B/c430 Audix ADX51 Sennheiser e914/e614	Medium	
6	Tom	Sennheiser e604/e904	Clamp	
7	Floor Tom	Sennheiser e604/e904	Clamp	
8	OverHead Stage left	AKG c451B/c391B/c430 Audix ADX51 Sennheiser e914/e614	Large	
9	OverHead Stage right	AKG c451B/c391B/c430 Audix ADX51 Sennheiser e914/e614	Large	
10	Bass DI			Amp DI out
11	Bass Mic	Audix D2/D3/D6 Shure Sm57 Sennheiser e906/e609	Small	
12	Guitar Rythm left	Shure Sm57 Sennheiser e906/e609	Small	
13	Guitar Rythm right			Amp DI out
14	Guitar Lead center	Shure Sm57 Sennheiser e906/e609	Small	
15	Vocal Dry	Shure Sm58	Medium	Plate stand
16	Vocal Wet	Shure Sm58	Medium	
17	Synth			Mono DI out
18	Back Vocal 1	Shure Sm58	Medium	
19	Back Vocal 2	Shure Sm58	Medium	Optional